

# DMS 1000 extension

## Universal Measuring System

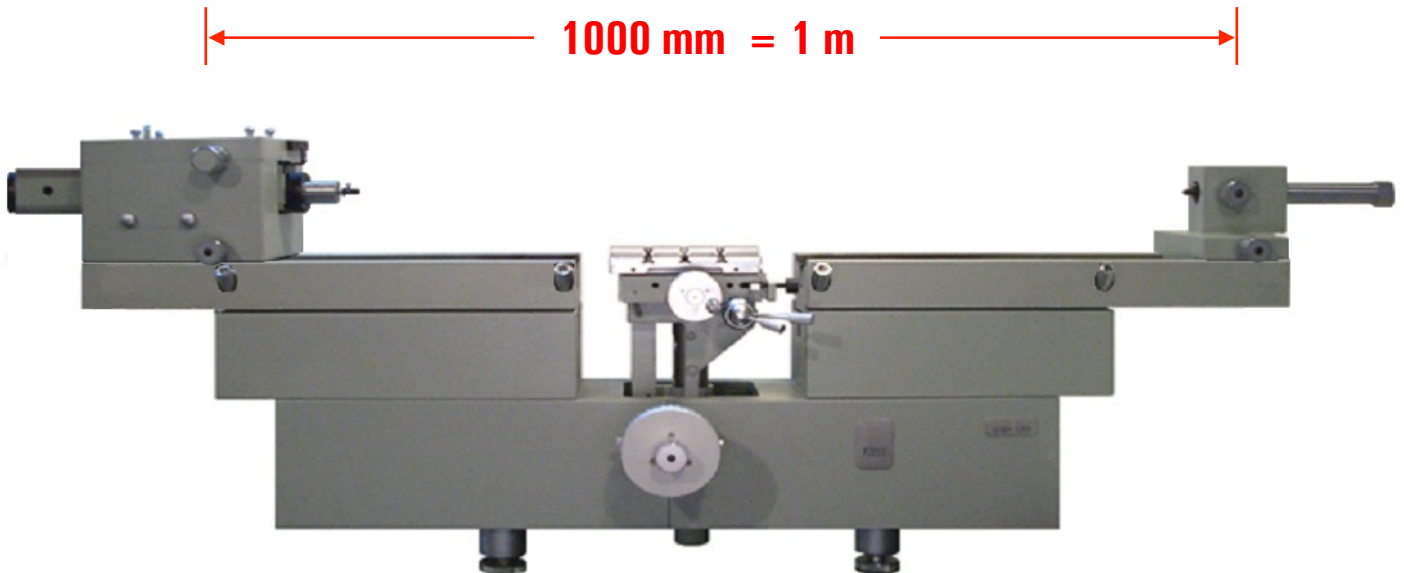

The DMS 680 can be equipped with a special extension to increase its capacity up to 1000 mm external.

**Applications** Main applications of the unit are the inspection of:

- long gage block
- plain plug gage
- plain ring gage
- thread plug gage
- thread ring gage
- snap gage
- pipe thread plug and ring gage
- bore gage
- external micrometer
- internal micrometer
- comparators
- electronic probe
- lever type comparator
- spline gage with involute profile and tooth gage



a brand-name of Microrep

## Large gage blocks measurement

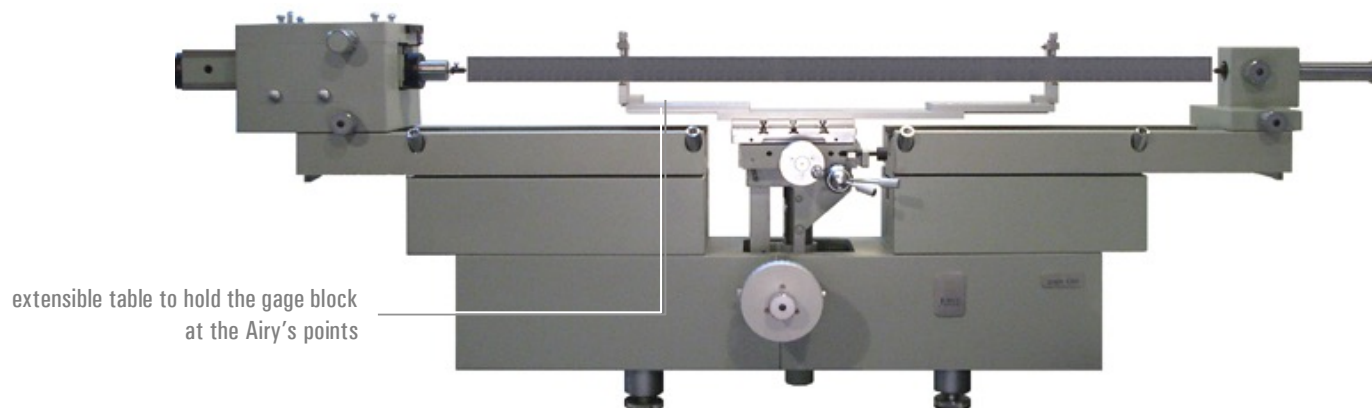

## Big micrometers inspections

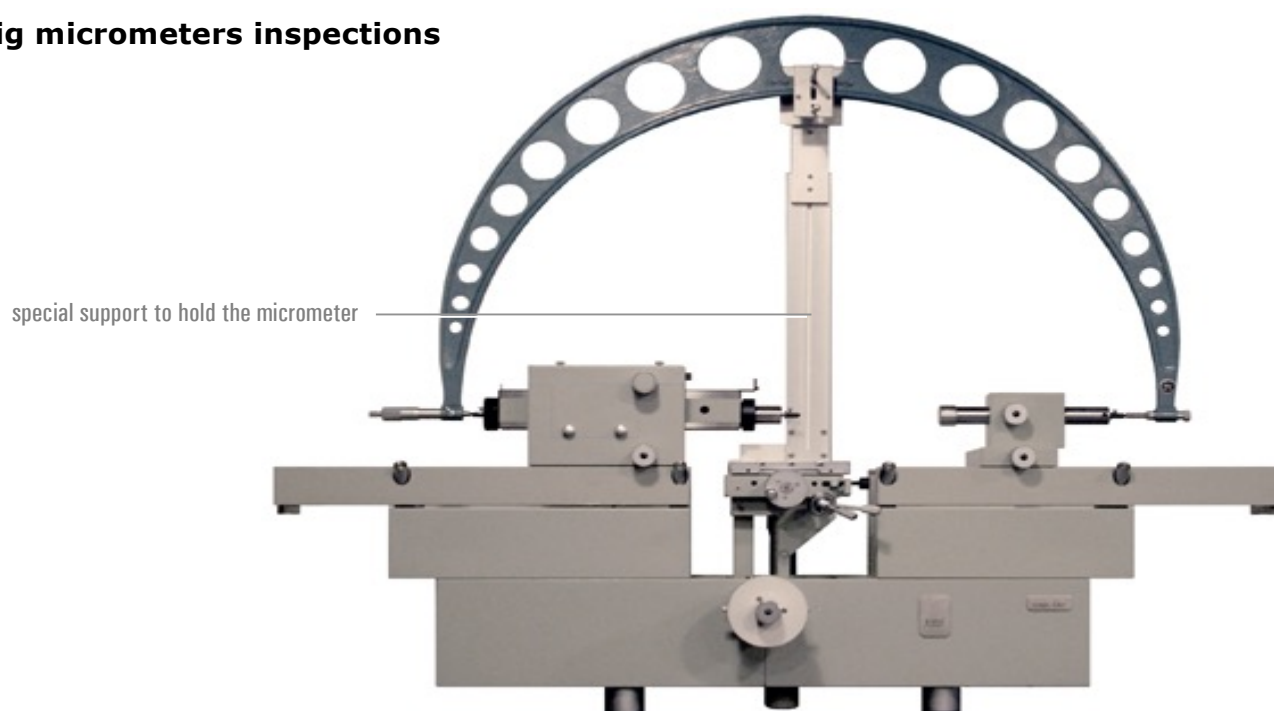

### Specifications

Absolute range	100	4"
Differential range	1000	40"
Applications:		
Long gage bocks	1000	40"
Micrometer for external	1000	40"
Resolution	0.1	

# MICROREP